

# M200-65

## AIR HYDRAULIC JACK

### M200-65

Mammut Air / Hydraulic heavy vehicle jacks are engineered and manufactured to offer all customers a lifting solution that is reliable, safe and easy to use.

- Lightweight, quiet, compact and easy to manoeuvre .
- Remote control as standard for extra safety.
- Folding handle.
- Wide range of models and capacities from 60 t to 200 t.
- Designed for tough Australian conditions.
- Pneumatic tires for easy operation.
- Internal check valves to prevent unintentional descent.
- Load blocks available for mechanical lock and to turn jack into a jack stand.

### TECHNICAL DATA

	M200-65
Capacity	200 t / 220.4 ton
Net weight	385 kg / 848 lb
Working air pressure	10-12 bar / 145-174 psi
Air consumption	600 nl/min
Max. height	1000 mm / 39.3 in
Min. height	650 mm / 25.5 in
Number of pistons	1
Stroke	350 mm / 13.7 in

### ACCESSORIES

#	Accessories
LBS200-65	Safety Blocks Kit
M4935	Extension Holder R
M4936	Extension Holder L
M4930	200mm Extension
M4931	250mm Extension
M4932	300mm Extension
A04495	Tilt Saddle

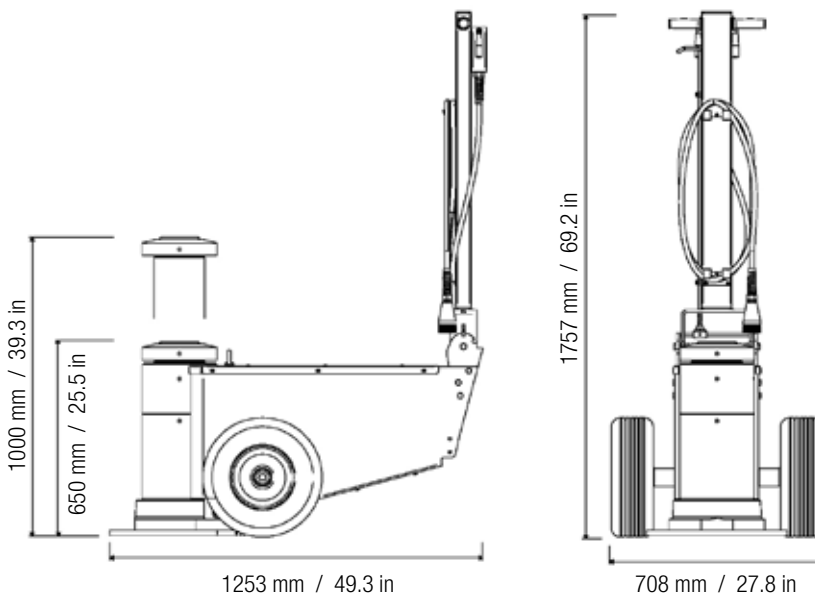



# M200-65

## AIR HYDRAULIC JACK

