

# M100-72-ATLAS

## AIR HYDRAULIC JACK

### M100-72-ATLAS

ATLAS Air / Hydraulic locking heavy vehicle jacks are engineered and manufactured to offer all customers a lifting solution that is reliable, safe and easy to use.

- Lightweight, quiet, compact and easy to manoeuvre.
- Two in one Jack that can also mechanically lock and turn into a jack stand
- Mechanical safety lock sealed inside the cylinder unit to protect it from dirt and dust
- Remote control that operates lift and lock.
- "Safe Load" LED indicators
- Folding handle.
- Designed for tough Australian conditions.
- Pneumatic tires for easy operation.

### TECHNICAL DATA

	M100-72-ATLAS
Capacity	100 t / 110.2 ton
Net weight	427 kg / 941 lb
Working air pressure	10-12 bar / 145-174 psi
Air consumption	600 nl/min
Max. height	1062 mm / 46.9 in
Min. height	722 mm / 28.4 in
Number of pistons	1
Stroke	340 mm / 13.3 in

### ACCESSORIES

#	Accessories
M4935	Extension Holder R
M4936	Extension Holder L
M4930	200mm Extension
M4931	250mm Extension
M4932	300mm Extension
A04495	Tilt Saddle

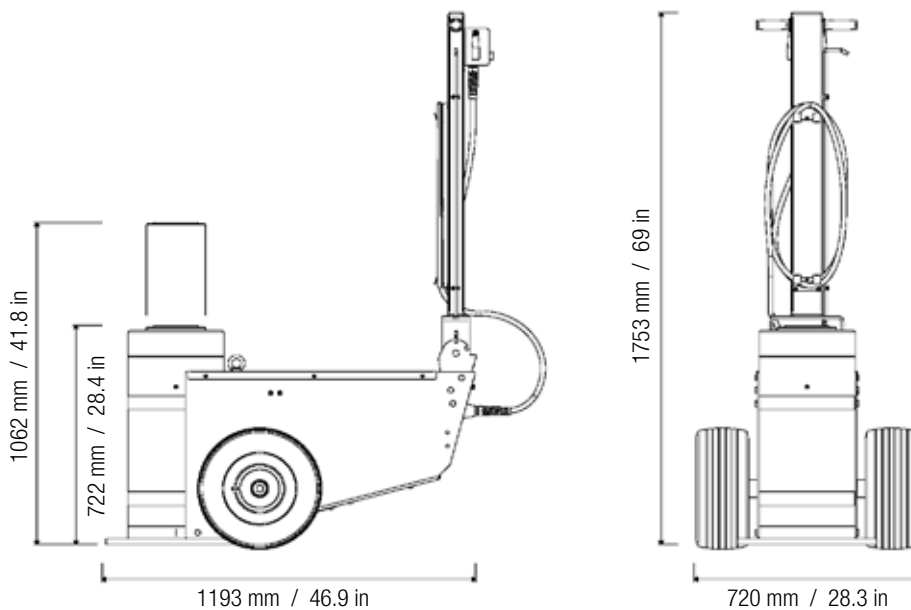



# M100-72-ATLAS

## AIR HYDRAULIC JACK

